

Meadows & Passmore

MERCURY BAROMETER FILLING KIT INSTRUCTIONS

With this kit you can fill, empty, clean and re-fill almost all wheel barometer tubes without a vacuum pump. It cannot guarantee a 100% vacuum, but an effective working reading can be obtained.

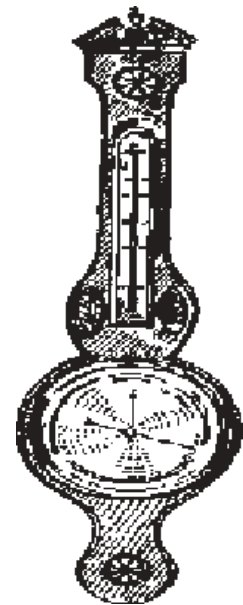

Please read and understand the instructions fully before attempting to fill or drain a tube.

The kit contains:

A syringe, fine capillary tube with connector and a length of plastic coated stainless steel wire.

You will also need the following:

A wooden filling tray
Masking tape
A razor blade
A non-metallic dish (an old but clean margarine tub will do)
A large non-metallic drip tray
Safety glasses
An assistant

and in case of spillage:

Sulphur powder
Calcium hydroxide powder
Don't wait until you spill it to get them!

Always wear eye protection. Remove jewellery. Work in an orderly manner on a clear bench in a proper workplace. Use a large non-metallic drip tray to place your tools on. Mercury is very hard to pick up after a spillage, and a tray will make it much easier. Any spillage must be collected as well as possible, and the residue treated with a dry 1:1 mixture of sulphur and calcium hydroxide. This will convert the mercury to a compound which is relatively harmless and can be swept up. **Mercury is very heavy and a liquid, and glass is very fragile.** This combination demands great care.

Mercury is a toxic substance.

The following Health & Safety information applies. The vapour and spillage on clothes and skin applies to all quantities. By use of the filling tray described in these instructions, surplus mercury can be recovered safely, and any residue can be treated with the sulphur and calcium hydroxide mixture.

Mercury precautions:

The metal should not be left exposed to air for long and should never be heated *except in an efficient fume cupboard*. The greatest risk is to technicians exposed to small vapour concentrations over a long period when symptoms may be mild and their onset gradual and unnoticed.

Dangerous with:

Aluminium. May set on fire
Ammonia. Explosive solids formed over a period of contact
Bromine. Violent reaction
Alkali metals. Violent reaction

If swallowed: Oddly enough there is little danger but get medical attention.

If vapour inhaled: Dangerous short term exposures are likely only if the metal was heated in which case get medical attention.

If spilt on clothes or skin: Remove contaminated clothing. Carefully wash affected area. Check jewellery for silver coloured staining (amalgam). A gold ring may be heated gently *in a fume cupboard* to drive off mercury.

If spilt: In the event of large spills, use a squeegee to suck up the bulk and then use a freshly prepared paste of copper powder mixed with bench dilute hydrochloric acid to soak up the drops. Spread dry 1:1 mixture of lime (calcium hydroxide) and flowers of sulphur in inaccessible areas where mercury may be lurking.

Disposal: Only by competent disposal authority. Dirty mercury should be kept for later purification.

Store: Under lock & key. Keep a stock of dirty mercury and send for purification regularly. Do not attempt to clean it yourself, except to remove surface dirt by shaking with Sellotape in a strong bottle.

Leave the tube in a warm dry room for 24 hours before filling. A change in atmosphere can cause condensation within the tube.

Always make sure the tube fits the case before filling. Make any minor adjustments to the case while the tube is still empty.

If you are emptying or filling even one wheel tube, a wooden filling tray is essential. Assemble one as shown and varnish it to prevent small drops of mercury getting into the joints. An alternative is to use square section plastic guttering with a stop-end fitted to the lower end. Mercury must not come into contact with metal of any kind and any spillage must be dealt with properly.

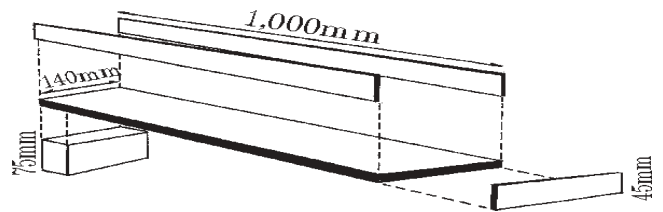

TO FILL A CLEAN DRY TUBE

Insert the short length of large diameter plastic tube into the float chamber so that one end *almost* touches the entrance to the glass capillary tube. Tape the tube to the glass, about 2" (50mm) from the free end. Place the barometer tube on the wooden tray with the vacuum chamber at the bottom and the float chamber vertically above the tube. Tape it down securely with masking tape in several places along the capillary section. Avoid tape at the very top, as this will limit your vision.

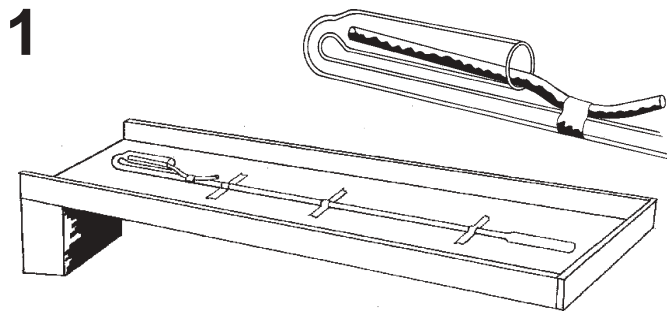

Insert the plastic covered steel wire into the fine plastic tube through the end with the syringe connector. Push gently, keeping the tubing as straight as possible. Remember the plastic tube is very delicate. Do not be tempted to use a lubricant, as this will contaminate the mercury.

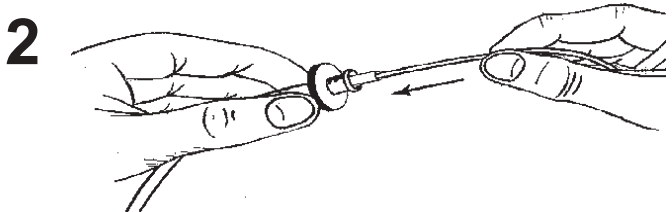

Insert the plastic tube (with the wire inside) through the larger plastic tube and into the glass capillary. Pushed gently and slowly it will go round the sharpest of corners. Continue pushing until the coloured end reaches the vacuum chamber.

Holding the syringe connector, gently pull the plastic covered wire back out of the fine tube. If you pull too quickly, the fine tube will bunch up and be damaged.

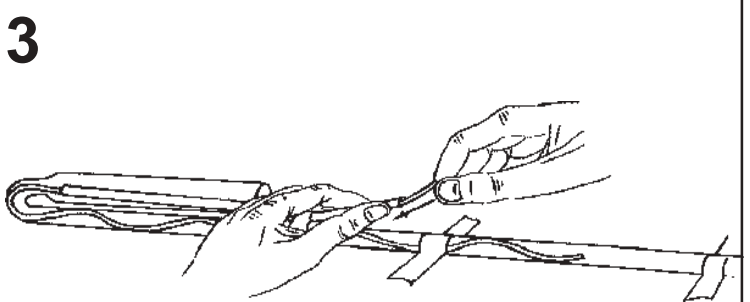

Pour enough mercury to fill the barometer tube into a non-metallic dish on the non-metallic drip tray and put the bottle away safely. Load the syringe with mercury, and invert it while still over the dish. Remember that mercury is about 13 times heavier than water, so it will do exactly the same in terms of dripping, siphoning etc. but 13 times more readily! Fit the syringe connector tightly onto the syringe and place it downwards on the tray. Any air in the syringe will be at the top with the plunger.

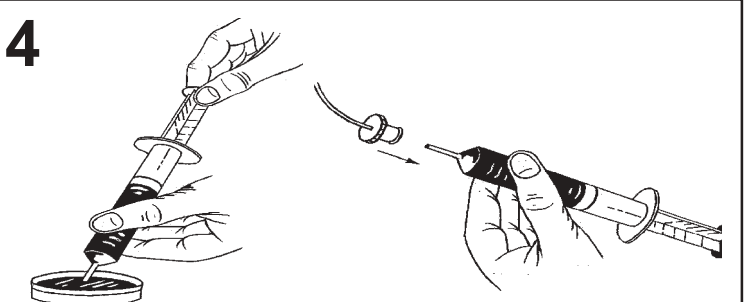

Very gently, squeeze a little mercury into the tube. You will see it as it passes through. Make sure that the tube is within the sides of the wooden tray, as it has now become very heavy. Once started, the mercury may begin to siphon out of the syringe into the vacuum chamber. You can control it by pushing and pulling the syringe plunger, but be gentle. One millimetre of the plunger is a lot of mercury in such a fine tube, and too much pressure could damage one of the fine joints or the syringe connector causing it to burst.

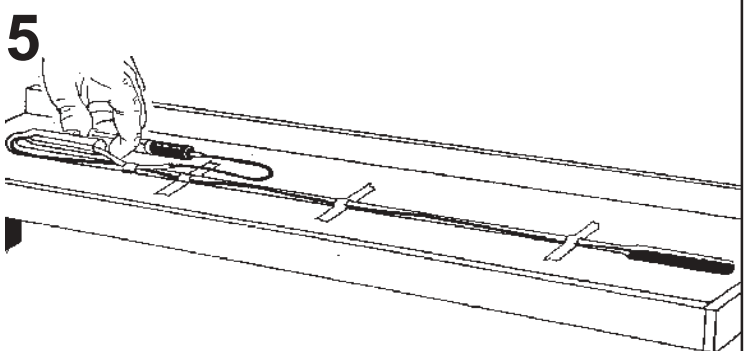

Fill the vacuum chamber with mercury. Watch out for trapped air at the point where the vacuum chamber joins the capillary. If you get some, ask an assistant to very slightly raise the angle of the wooden tray while you add the mercury. Once past the neck, lower the tray again. This is the only time during the process that you should raise the tray or the tube.

6

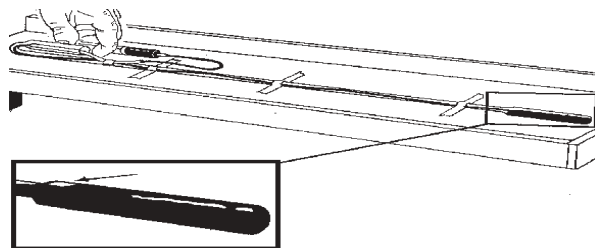

Fill the capillary tube with mercury, withdrawing the fine tube as you go. Always keep the coloured end of the tube in the mercury. If you leave it in too far, it will get stuck. If you pull too hard, it will distort. If it gets stuck, draw a little mercury back into the syringe, and then continue as before. Should you find there is not enough mercury in the syringe, never remove the syringe connector to recharge it while holding it below the level of mercury in the tube or it will siphon out. An airlock in the fine tube does not matter, because the presence of the plastic reduces the mercury's surface tension and the trapped air can get past. Fill the tube right up to the U bend. Withdraw the fine tube completely and place it on the plastic tray.

7



Cut the masking tape around the larger plastic tube and remove the tubing completely. Place it on the plastic tray.

8

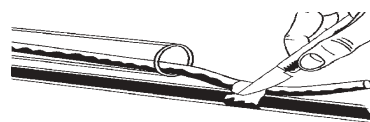

With your assistant holding the tube in position, remove the remaining tape. Gently raise the vacuum chamber end, keeping the float chamber above the capillary tube. When the vacuum chamber top reaches the barometric pressure height, surplus mercury will pass round the U bend and into the float chamber and the vacuum will form. Carefully raise the tube to the vertical position.

9

From this point onwards, *never lower the vacuum chamber end without extreme caution*. Any sudden movement will cause the mercury to return to the end of the tube, and because of its weight, it may smash through the end, scattering mercury and glass all over the room.

Vacuum

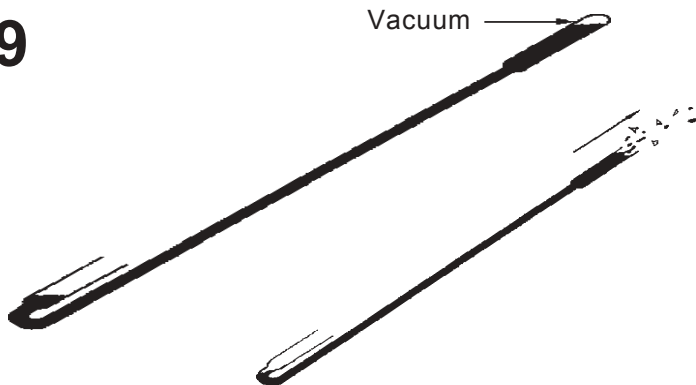

To transport the tube filled, add a few extra drops of mercury while holding the filled tube vertically. Very carefully, lower the tube half-way back down, watching not to let the mercury hit the end of the vacuum chamber hard. (You may hear the thud as it reaches the end). Insert a plug into the start of the capillary tube. Fit the cork into the float chamber firmly. Now, when the tube is raised and lowered, the risk of damaging the glass tube is much less, but only as secure as the plug!

10

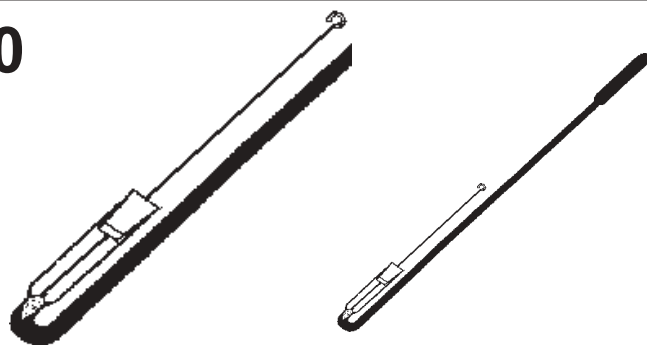

If you spill mercury, recover as much as possible using a plastic scoop, an old syringe or similar. Do not use a vacuum cleaner, as this will become a constant source of mercury vapour. Tip any mercury in the wooden tray into a bottle of waste mercury. Treat any contaminated area with a 1:1 mixture of dry Sulphur:calcium hydroxide powder and sweep up. If you need assistance, contact your mercury supplier or our technical department at once. READ THE HAZARD DATA ON PAGE 1 IF NONE CAME WITH YOUR MERCURY.

TO EMPTY A TUBE

Surprisingly, this is more difficult than filling one. **Never introduce the plastic tube or the wire into the glass tube while the vacuum chamber is at the top, or turn it that way up after inserting either of them.** The presence of the plastic reduces the surface tension of the mercury and air will suddenly pass into the tube, allowing the mercury to come out uncontrollably.

Never try to remove mercury from the float chamber by siphoning it out with the syringe. By reducing the height of the mercury to less than the barometric level, air can be drawn into the capillary. The vacuum at the top will be lost, and the mercury will smash its way through the glass and shoot all over the room.

To remove the mercury safely, hold the tube over the wooden filling tray, with the U bend touching the wood at the higher end. Gently lower the vacuum chamber until it touches the wood. A little mercury will fall from the float chamber and run down the wood tray to the bottom. This can be collected later. Tape the glass tube in position, as if it was going to be filled.

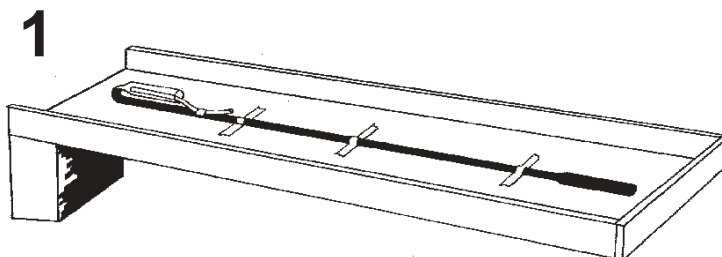

Insert the short length of large diameter plastic tube into the float chamber so that one end almost touches the entrance to the glass capillary tube. Tape the tube to the glass, about 2" (50mm) from the free end.

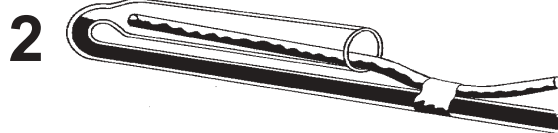

Insert the plastic tube (without the wire inside) through the larger plastic tube and into the glass capillary. Pushed gently and slowly it will go round the sharpest of corners. Because the tube is filled with mercury, you will not be able to push the tube right down to the bottom. Fit the syringe to the connector, and withdraw some mercury. Repeat the process of inserting more tube and withdrawing liquid until the tube is completely empty.

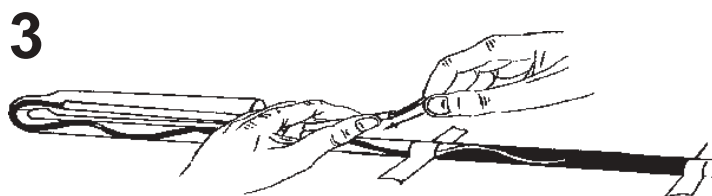

On some older tubes, the capillary is so fine that you will be unable to insert the fine tube without the plastic covered steel wire inside. If this is the case, remove the fine plastic tube and insert the plastic covered steel wire inside it through the end with the syringe connector. Push gently, keeping the tubing as straight as possible. Remember the plastic tube is very delicate. Do not be tempted to use a lubricant, as this will contaminate the mercury. Insert the fine tube again, as far as you can into the mercury. Liquid will be displaced. Allow this to leave by the float chamber and run down the wooden tray to be collected later.

When the tube reaches the vacuum chamber, remove the plastic covered steel wire by holding the syringe connector and gently pulling the plastic covered wire back out of the fine tube. If you pull too quickly, the fine tube will bunch up and be damaged. Re-connect the syringe and withdraw the mercury.

If the tube won't go to the bottom at first, repeat the process of inserting, draining and re-inserting until all the mercury has been removed.

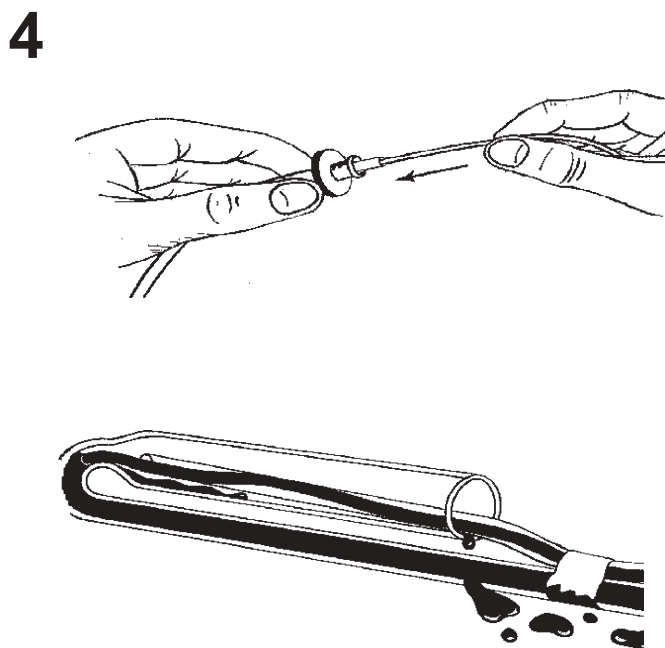

TO CLEAN A USED TUBE

It is generally considered easier and cheaper to replace an old tube rather than drain, clean and refill one. However, some barometers have unusual shaped tubes, and these are not readily replaced.

To clean an empty tube, insert the short length of large diameter plastic tube into the float chamber so that one end *almost* touches the entrance to the glass capillary tube. Tape the tube to the glass, about 2" (50mm) from the free end.

1

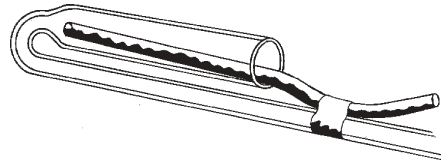

Insert the plastic covered steel wire into the fine plastic tube through the end with the syringe connector.

Push gently, keeping the tubing as straight as possible. Remember the plastic tube is very delicate.

2

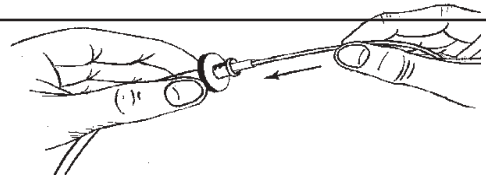

Insert the plastic tube (with the wire inside) through the larger plastic tube and into the glass capillary. Pushed gently and slowly it will go round the sharpest of corners. Continue pushing until the coloured end reaches the vacuum chamber. Tape the glass to a work surface or drainer if this is more convenient.

3

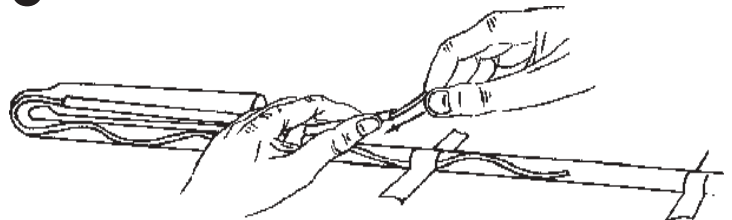

Holding the syringe connector, gently pull the plastic covered wire back out of the fine tube. If you pull too quickly, the fine tube will bunch up and be damaged.

Charge the syringe with a 7:1 water : Medmaw cleaner mixture and attach the connector. Fill the barometer tube, leaving the fine tubing in place. When filled as far as the U bend, raise the vacuum chamber to the vertical position. Top up the float chamber with liquid to the brim, and leave it that way up for several hours to soak. Provided you do not remove the syringe from the connector, it should not siphon out.

4

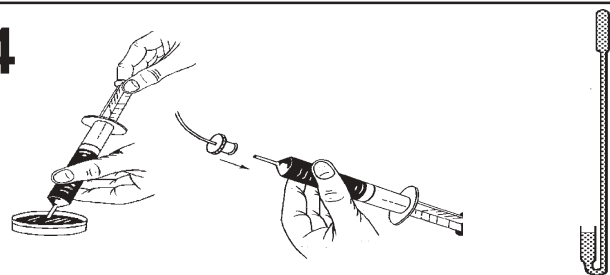

Withdraw the mixture from the glass tube either by drawing it back into the syringe, or replacing the used mixture with fresh. You can replace, rinse and re-charge the tube as often as needed until it is quite clean. Always rinse with fresh clean water at least 7 times to ensure that all trace of the cleaner is gone. Withdraw the fine tube carefully and dry the outside and the syringe with a clean cloth. Pass dry air through the fine tube using the syringe repeatedly.

5

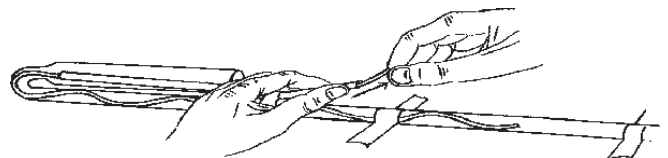

Stand the tube upright so any water drains into the U bend. It may collect at the bottom, blocking the tube. To remove it, hold the vacuum chamber in your hand. The warmth will expand the air, forcing the water along the tube. Repeat until the tube is free of water. Dry by re-inserting the fine tube and passing air via the syringe into the vacuum chamber. This forces the moister air out the other end. To speed up the process, a model-makers compressor can be fitted to the connector, provided that the pressure can be reduced sufficiently. Finally, leave it in a warm dry place.

6

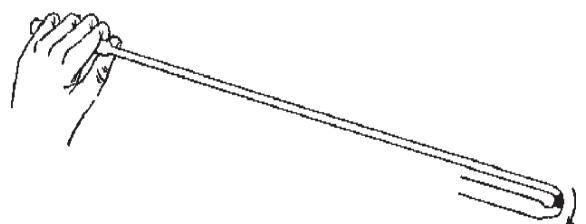

Accessories available from Meadows & Passmore

BAROMETER TUBES

Wheel tubes made from Pyrex glass complete with float, counter-balance and counter-balance tube. Pyrex is used to avoid the mercury staining that occurs on soda glass. The tubes are very high quality, and the float is a very accurate fit. This reduces the evaporation of toxic mercury vapour to minimal levels, and also ensures that small changes in pressure register. 3mm capillary. Mercury capacity nominally 160g. Supplied un-filled.

0780000115

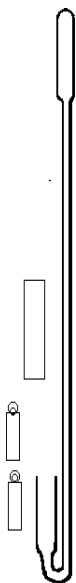

BAROMETER TUBE FILLING KIT

With this simple kit you can drain, clean, rinse and refill old tubes and of course fill our new tubes with mercury. Kit includes a syringe and fine tubing that will go around the U bend of most tubes, (even below 1 mm bore). Supplied with detailed and illustrated instructions. Cleaning fluid, mercury etc. not included.

Kit **0796000115**

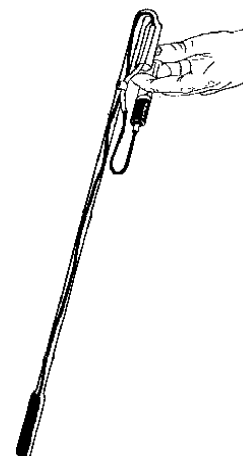

BAROMETER TUBE CLEANER

If you plan to use our kit to drain, clean and re-fill an old tube, you will need this concentrate to remove as many of the stains as possible. Dilute with 5 parts of warm water. You will need our filling kit to insert the cleaner and to rinse and dry the tube.

125ml **0799012515**



MERCURY

Triple distilled mercury to BS 4227, packed in 175g plastic bottles. Mercury is toxic, and the vapour is particularly dangerous. If you are uncertain about its use, we suggest you find someone to handle it for you. Be sure to have sulphur and calcium hydroxide available in case of a spillage. Please do not wait for a spillage and then order the powders in a panic!

The Royal Mail will not accept a package containing mercury. We have to use another carrier to deliver this to your door.

175g **0797017515**



Current prices of these items are available upon request. Our parts catalogue contains many other items for barometers & clocks

WHEEL TUBE PLUG

Insert this plug into the capillary when the tube has been filled with mercury. It will protect the tube by stopping the vacuum until you are ready to fit the float etc.

0910000115



MERCURY SPILLAGE POWDERS

In the event of minor spillages of mercury, recover as much as possible. Treat any residue with a dry mixture of 1:1 sulphur/calcium hydroxide. Sold in packs of 250g of each, making a 500g pack.

500g. **0798050015**



