

CLOCK CHAINS

Where the original clock chain is present and fits the clock, a suitable replacement can be found by measurement and comparison with our chain list. In cases where the chain is missing, or the fitted chain does not match the sprockets, the following formula should establish the nearest chain to use:

Count the total number of sprockets on the chain wheel.
Our example has 8:

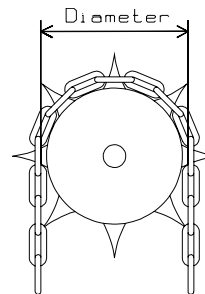
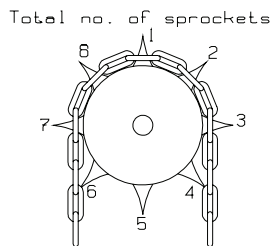

Measure the effective diameter of the pulley excluding the sprockets, in mm. If the sprockets are wider at the base, as in our example, the effective diameter is the lowest point on the sprockets reached by horizontal links. This should be apparent by wear marks. Our example is 30 mm.

THE FORMULA:

$$\left(\frac{\text{Diameter} \times 3.14}{\text{Total no. of sprockets}} \right) \div 2 \times 1.1 = \text{Internal length of 1 link}$$

We have devised this simplified formula as a general rule to assist with chain selection. It is only a guide!

Or:

- Multiply the diameter by 3.14.
- Divide the answer by the number of sprockets.
- Divide this answer by 2.
- Multiply that answer by 1.1.

Our example:

- 30 x 3.14 = 94.2
- 94.2 / 8 = 11.78
- 11.78 / 2 = 5.89
- 5.89 x 1.1 = **6.48mm internal link length.**

Refer to our comprehensive list for a chain that has an internal link length close to the answer, and whose external link width will fit well between the sides of the chain wheel. If you select a chain link shorter or much larger than the answer, it will probably 'ride up' over the sprockets.

Clock chain is one of the most difficult items to select and purchase by mail order. Frequently the sprockets are worn, or the wrong chain has been fitted. We get samples sent to us like bathroom chain which of course we cannot match. If you have got a piece of chain that fits, measure the internal link length. Refer to the list, and verify your choice by placing it over the drawing on the next page. If you have no chain, or the one you have does not fit, make sure that the clock is not designed for rope. There must be somewhere for the alternate links (the ones not over the sprockets) to go. Rope driven clocks don't have this, and you cannot just fit chain to a rope clock. Rope driven clocks often have sprockets that are not carefully set. Chain sprockets have to be equally positioned to match the chain pitch - rope sprockets can be anywhere around the circumference. The formula on the opposite page is a simplified way of working out what a missing chain should be like.



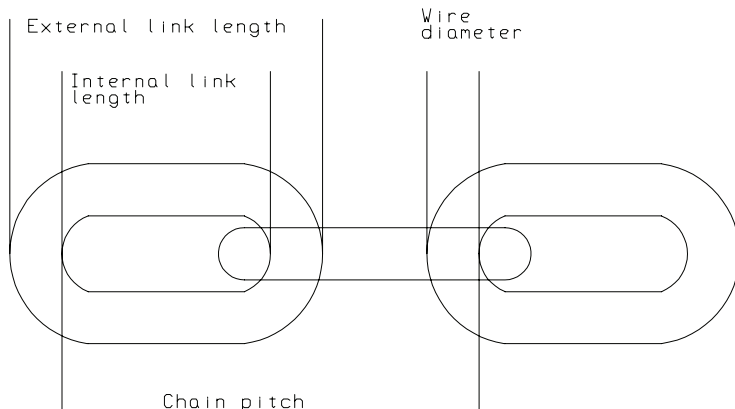













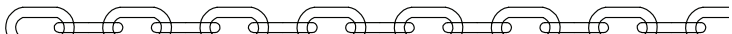

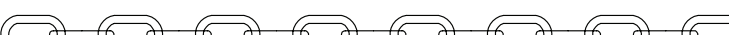
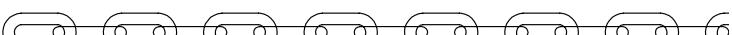

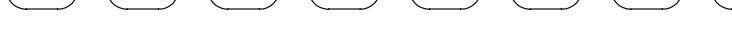

Please don't send us lengths of chain to match up. If you need help selecting a chain, send us the internal pulley from the clock and we will try to find one that fits. Our samples charge will be applied to all chain enquiries, and extra return postage will be incurred.

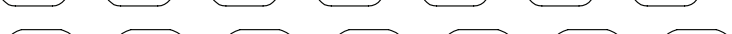
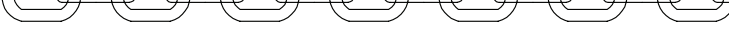

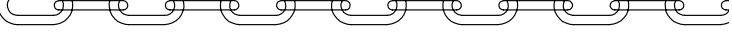
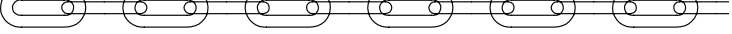
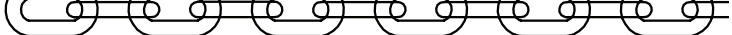
Finish:
When we say iron, we mean either self coloured steel or nickel plated steel. Brass means solid brass or brass plated steel. We cannot specify the exact material as the manufacturers vary it according to material availability.



CLOCK CHAIN DRAWINGS

Part numbers

	0388 004615
	0388 001915
	0388 015815
	0388 001315
	0388 010014 & 18
	0388 003714 & 15
	0388 003915
	0388 004415
	0388 001218
	0388 000114
	0388 014715
	0388 014615
	0388 010314 & 18
	0388 015914
	0388 010614 & 18
	0388 004215
	0388 014014 & 15
	0388 010414 & 18
	0388 010114 & 18
	0388 000618
	0388 010514 & 18
	0388 010914
	0388 013615
	0388 003614
	0388 003315
	0388 010814
	0388 010714

Appendix

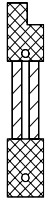
SUSPENSIONS (actual size)

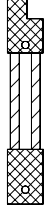
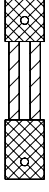
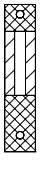
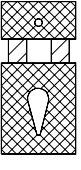
						A 0297 000115
A	B	C	D	E	L	B 0298 000115
						C 0299 000115
						D 0347 000115
						E 0300 000115
						L 0513 000115
						V 1310 004615
						X 1310 000715
						Y 1310 003515
						Z 1310 005215
						W 1310 005115
						AA 0319 000115
						F 0336 000115
						G 0337 000115
						H 0338 000115
						J 0339 000115
						K 0340 000115
						R 0672 000115
						S 0925 000115
						T 1089 000115
						U 1089 000215
						M 0560 000115
						N 0560 000215
						P 0560 000315
						Q 0560 000415

M, N, P & Q are supplied complete with brass leader, 60 x 5mm and rivet.

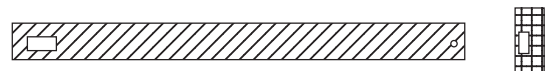

CYCLOIDAL CLOCK & WATCH WHEEL & PINION CUTTERS

A range of finest quality cutters made from high speed steel hardened and treble tempered under vacuum. This steel, with a hardness circa 68 Rockwell C. maintains a good cutting edge which offers long periods between sharpenings.

Brass for wheels should be hard or half-hard, with a typical composition of 61-64% copper, 1-2% lead and the balance zinc. Soft brass will clog the cutter.

Steel for pinions should be free cutting silver steel with a typical composition including 1% Carbon, 0.55% Manganese and 0.20% Selenium

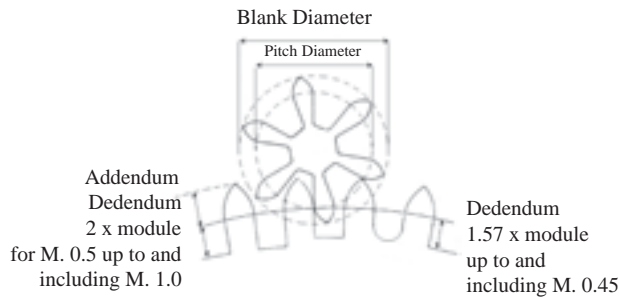

No. of leaves	Ogive	Ratio Tooth space	Add to number of teeth or leaves
6	Full	1/2	1.71
7	Full	1/2	1.71
8	Full	1/2	1.71
10	1/3	2/3	1.61
12	1/3	2/3	1.61
16	1/3	2/3	1.61
Wheel	-	1/1	2.76

CALCULATION OF THE MODULE

Module M = Pitch circle diameter in mm (D) / No. of teeth in wheel or leaves in the pinion (N)

Also M = Twice the centre distance in mm / Sum of teeth in wheel and pinion

CALCULATION OF BLANK DIAMETER

Blank diameter = Module x (N + addendum allowance from table above).

Example: for a pinion of 6 leaves and a Module of 0.7,
Blank diameter = 0.7 x (6 + 1.71) = 5.397 mm.

Note that this enables the module of a wheel or pinion to be found when the centre distance is not known.



For Module M = Tip diameter / N + Addendum allowance.

For odd pinions of say 7 leaves use a hole gauge to measure the tip diameter

PROFILE DIMENSIONS FOR CLOCK & WATCH WHEEL & PINION CUTTERS

PINIONS

All dimensions as ratios of the module. M millimetres BS 978 : part 2. As Swiss Standard NHS 56703 except for*

Number of leaves	6	7	8	10	12	16
Pitch circle diameter	6 x M	7 x M	8 x M	10 x M	12 x M	16 x M
Outside or Tip diameter (diameter of blank)	7.71 x M	8.71 x M	9.71 x M	11.61 x M	13.61 x M	17.61 x M
Root diameter*	2.5 x M	3.3 x M	4.2 x M	5.9 x M	7.8 x M	11.8 x M
Leaf thickness	1.05 x M	1.05 x M	1.05 x M	* 1.25 x M	1.25 x M	1.25 x M
Addendum radius	1.05 x M	1.05 x M	1.05 x M	0.82 x M	0.82 x M	0.82 x M
Form of addendum	Full Ogive , profile "C" (r = leaf thickness)			1/3 ogive, profile "B" (r = 2/3 of a leaf thickness)		
Angle of cutter flank	20°	17°- 9'	15°	10° - 48'	9°	6°-45'
Tooth/pitch ratio	1/3	1/3	1/3	2/5	2/5	2/5
Addendum	0.855 x M	0.855 x M	0.855 x M	0.805 x M	0.805 x M	0.805 x M
Dedendum	1.75 x M	1.85 x M	1.90 x M	2.05 x M	2.10 x M	2.10 x M
Full tooth depth (depth of feed)	2.605 x M	2.705 x M	2.755 x M	2.855 x M	2.905 x M	2.905 x M
Length of cutting edge or profile for M. = 1.0	6.58 x M	6.90 x M	7.11 x M	7.38 x M	7.59 x M	7.75 x M

Appendix

WHEELS

All dimensions as ratios of the module. M millimetres BS 978 : part 2. As Swiss Standard NHS 56702 except for*:

Module M.	Up to and including 0.45, and 1.1 to 1.5	0.5 and up to and including 1.0	Short Form 0.2 to 1.0
Number of teeth	N	N	N
Pitch circle diameter	N.x M	N x M	N x M
Outside or Tip diameter (diameter of blank)	$(N + 2.76) \times M$	$(N + 2.76) \times M$	$(N + 2.76) \times M$
Root diameter	$(N - 3.14) \times M$	$* (N - 4) \times M$	$(N - 2.14) \times M$
Tooth thickness	1.57 x M	1.57 x M	1.57 x M
Addendum radius	1.93 x M	1.93 x M	1.93 x M
Angle of cutter flank	2°	2°	2°
Addendum	1.38 x M	1.38 x M	1.38 x M
Dedendum	1.57 x M	* 2 x M	1.07 x M
Full tooth depth (depth of feed)	2.95 x M	3.38 x M	2.45 x M
Length of cutting edge or profile for M. = 1.0	8.18 x M	9.01 x M	7.18 x M

PINIONS SHOULD NEVER BE CUT DRY:

A copious stream of cutting oil should be used to keep the cutter cool and remove the chips.
(Mobilnet 745 or equivalent).

For cutting pinions for old work with thicker leaves, use cutter 0.05 module smaller than calculated. The addendum allowance is unchanged.

RECOMMENDED CUTTING SPEEDS:

For cutting carbon steel pinions with high speed steel cutters:

Cutter diameter 14 mm 430-500 rpm

Cutter diameter 20 mm 300-350 rpm

Cutter diameter 24 mm 250-290 rpm

Cutter diameter 26 mm 230-270 rpm

For cutting brass a speed of 3-400 rpm should be used.

TURNED HAND COLLETS

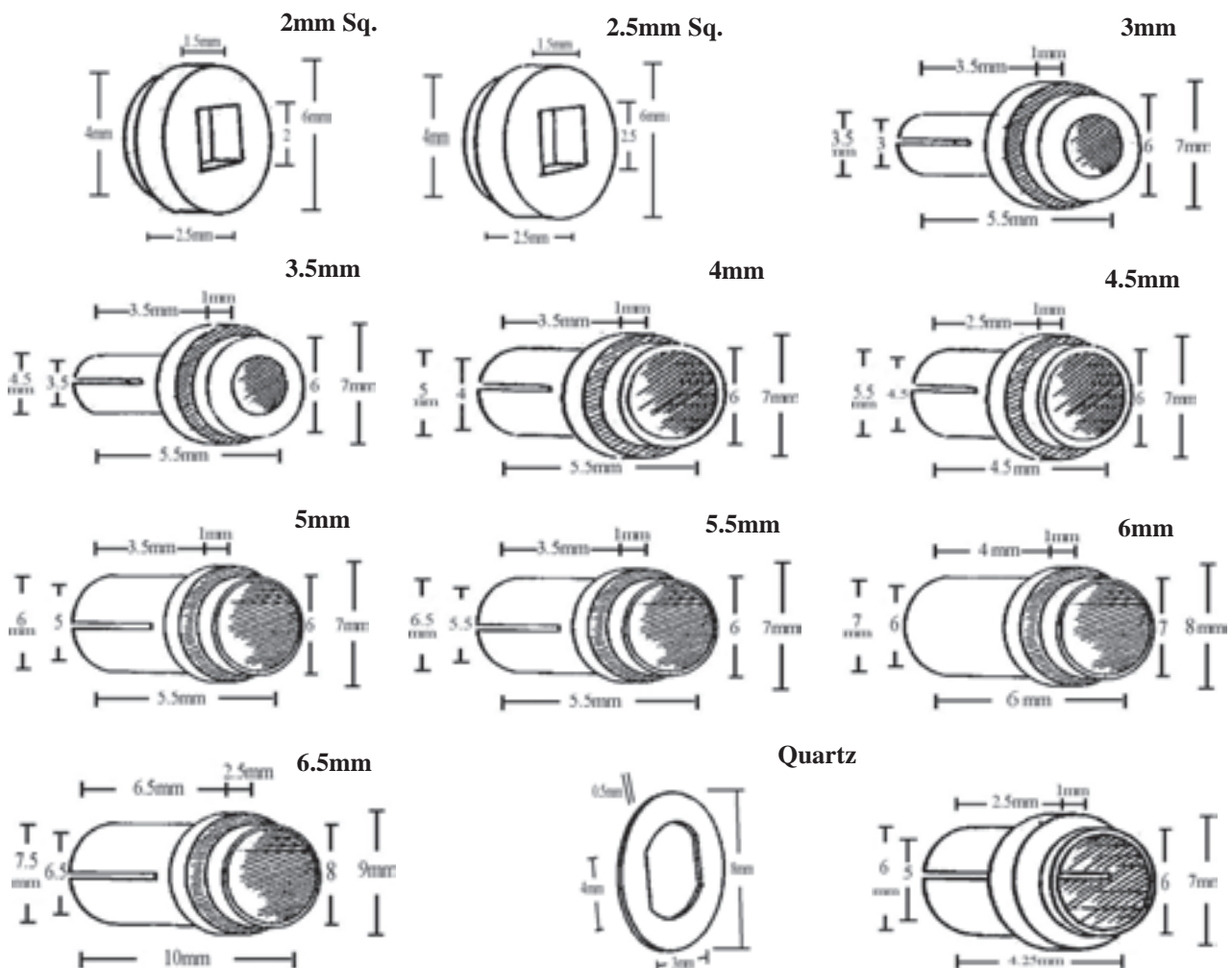

Hints on selecting bushes & broaches

We often get asked for assistance in selecting bushes and cutting broaches for clock repair purposes. This document assumes you are bushing by hand without the benefit of any outfit or depthing tool etc

Points to remember:

- Replace as little as possible of the original clock plate.
- Always bush from the inner face of the plate.
- Try to get the centre of the new bush where the *centre* of the original hole was before it became oval.
- Bushes need to be riveted in place when fitted by hand, so the inner hole will get slightly smaller.
- Attend to the pivot where necessary before contemplating bushing.

Cutting broaches are five sided, and tapered. The measurement given in the catalogue is the effective diameter of this 5 sided cutter, about 10mm from the shoulder. The taper is 0.01mm. so the diameter decreases about 1mm per 100mm in length. The length is listed in the catalogue, so you could, if you wished, estimate the starting diameter.

Select a bush simply by identifying the smallest one that can be used, and whose length is greater than or at least equal to the thickness of the clock plate. The outside diameter of this bush dictates which cutting broaches you will definitely need. You will need others to complete the work. Bergeon bushes increase in diameter in regular steps:

Bush diameter	Broach no.	Max. diameter.	M&P broach no.
2.00mm	42	2.33	0547 023315
2.50mm	36	2.69	0547 026915
3.00mm	30	3.22	0547 032215
3.50mm	26	3.70	0547 037015
4.50mm	12	4.70	0547 047015
5.50mm	A	5.94	0547 059415

The broaches listed above will enable you to enlarge a hole so that the bush is a tight fit. Broaches are tapered, so always work from the inside. This will prevent the broach from being able to work its way out in time.

Bushing by hand makes it much more difficult to start enlarging the hole from the original centre, and if you have a small bench drill you may find it more successful if you use a small twist drill to get started. Only use a drill to make a round starting hole from which to work.

Carefully enlarge the old hole with the broach. A useful way of holding a broach is not with a conventional wooden handle but a tap wrench. This will help you to keep the broach at right-angles to the plate. Check regularly that your hole is smaller than the bush you plan to use.

When the hole is just large enough for the bush to enter, consider carefully if it is now big enough to fit. This decision comes from experience, so always do your first bushing on a scrap clock plate.

When the hole is the right size, place the plate face down on a hard surface (protected in some way so as not to mark the surface), fit the bush with the oil sink downwards and rivet it in with a clockmakers hammer. The hammering process will spread the bush to make it a tight fit, and also help harden the brass.

With a bulls foot file, remove any surplus bush. You can also use a burr remover, with a clock pin inserted in it to act as a centring device.

Assuming you have attended to any wear on the pivot, measure the diameter and select a suitable cutting broach. Broach out the new hole to match the pivot. Smoothing broaches can be used to polish the inside face.

The oil sink can be improved dramatically by using a roller sinker. This will cut a neat oil sink and help disguise the fact that the clock has been bushed at all. In fact, well done re-bushing is almost invisible to the inexperienced.

SWISS PLATFORM ESCAPEMENTS

Extremely high quality Swiss units that over the years have become the 'standard'. 8 leaf escape wheels. Shown approximately to scale. Fully jewelled lever escapement. No endstones.

A - 18 X 28mm

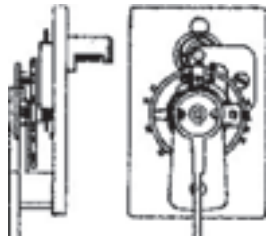

E - 30 X 41mm

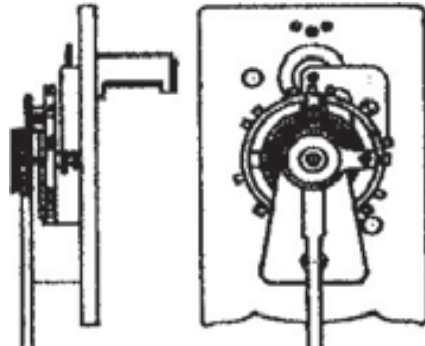

F - 23 X 36mm

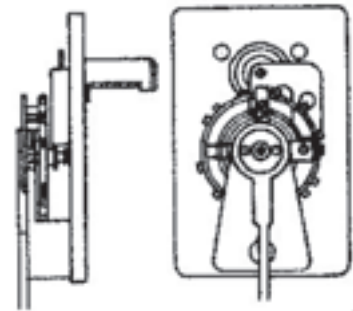

C - 25 X 36mm

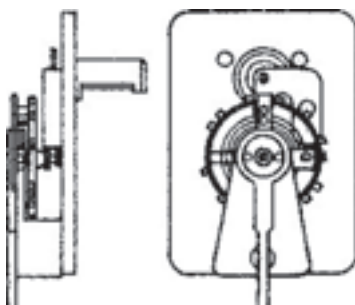

D - 24 X 44mm

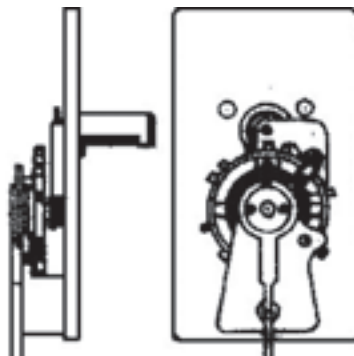

H - 34 X 45mm

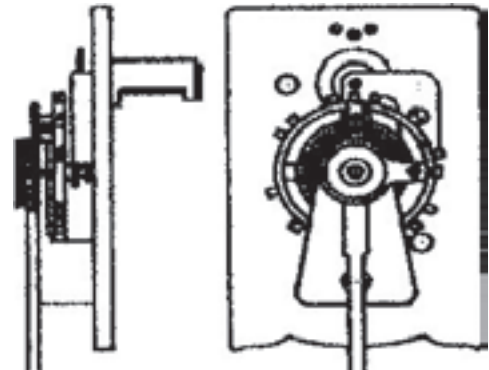

SELECTING A REPLACEMENT PLATFORM

Compare the original with the illustrations shown. The position of the pinion (F) must be correct in relation to the wheel (E). The top pivot can be seen in the illustrations. Select a size nearest the original and check that it will not obstruct the dial, case etc.

Escape Wheel Pinion Count

Modern escapements are supplied with 8 leaf pinions. Other counts are available but as they are not interchangeable the platform and pinion **must** be ordered together. We cannot give a refund on the 8 leaf escape wheel originally fitted. Replacement platforms have a frequency of 18,000 vibrations per hour and the escape wheels have 15 teeth. As there are two vibrations of the balance for each tooth, then it follows that the escape wheel must rotate 600 times per hour. That is: (18,000 divided by (15 x 2)). The centre wheel (to which the minute hand is directly attached) clearly rotates once per hour, so the gearing in between must have an overall ratio of 600:1.

To calculate the number of leaves that the pinion should have to give a ratio of 600:1, count the number of teeth on wheels A, C & E. Count the teeth on pinions B & D. The number of teeth on the escape wheel pinion is $(A \times C \times E) / (B \times D \times 600)$ You can count the number of leaves on the existing platform escape wheel if this is available, but it does not always follow that the natural frequency was 18,000. In the majority of cases this is so.

Our online technical support page includes a calculation tool to simplify this calculation process.

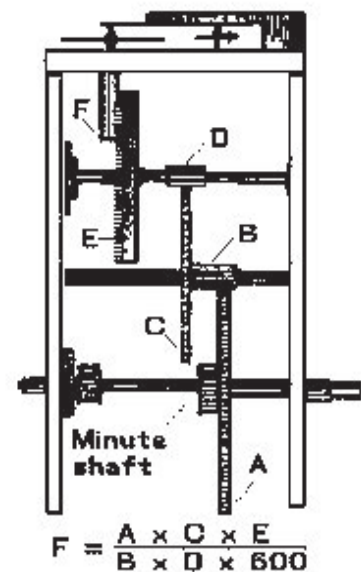

$$F = \frac{A \times C \times E}{B \times D \times 600}$$

CUSTOMERS' SAMPLES

We regret we can no longer offer to match goods against customers' samples. Please do not send clock parts, samples, lengthy written descriptions or photographs of items to us for identification or matching. Samples and customer's property sent to us will be returned unprocessed by uninsured ordinary mail.

Our catalogue should provide customers with sufficient information to establish if an item is suitable. Where further information would be helpful, please telephone or email our sales department. We will be happy to provide as much technical information on a product as we can, even if this is not available immediately. If any description in the catalogue is clearly insufficient, inaccurate or even misleading, it is not our intention. Your assistance in drawing any discrepancies to our notice is welcomed.

Customers who cannot establish the suitability of a stock item may order it on the basis that items not as anticipated may be returned unused for a refund. This must be done within 7 days and the sale number quoted. Additional postage will be charged for any alternative requested. No credit will be given for postage on items not as anticipated, which must arrive back in a saleable condition.

Customers can email photos of clocks or parts if there is a problem identifying an item. We regret we can give no advice on repairs or valuations, nor can we enter into correspondence about the suitability or identification of a part.

Please do not send cheques or postal orders made out for what you think the total will be. We cannot accept cheques from non account holders for anything but the invoice total and this depends on current prices, availability etc. You can send a cheque crossed and made payable to Meadows & Passmore, but with the amount left blank. For your own safety write across the cheque (and on the back if you wish) "Not to exceed £....." and insert a figure about 10% higher than you think the total will be. We will make out the cheque for the correct amount and advise you of the total and send a receipt. Remember, that **if you feel the price we have charged for an item is excessive, you can return it (in a saleable condition and quoting the invoice number) within 7 days for a refund.** Alternatively, you can **telephone during our office hours for the current cost of your order.** If you do send a cheque for a fixed amount which does not match the invoice, whether it be higher or lower, it will be returned unprocessed.

The Tropical Bank Plc.		Ivy Street Branch, Chichester, West Sussex PO19 1JH	
Pay <u>MEADOWS AND PASSMORE</u>		or Order	
		AMOUNT	
		£	
Specimen		For and behalf of:	
NOT NEGOTIABLE NOT MORE THAN FIFTY POUNDS AC-PAYEE ONLY		 Authorized Signature	
004920 30-92862 0475886*			

AUTOMATED SALES FREEPHONE

Most orders are sent postage free and despatched the same day if placed on our interactive order line.

0800 328 9435

Please call our sales office on 01273 421321 if you don't know your customer number and pin.

1,000's OF CUSTOMERS NOW USE OUR AUTOMATED SALES LINE BECAUSE THEY GET...

- Same day despatch*
- Free postage & packing**
- Free 0800 phone call
- 24 hour operation
- Price & availability info
- Technical data
- Details on recent orders

Call Harvey on
0800 328 9435

All backed up by our huge range of products, massive stocks and competitive prices.

HOW DO I USE IT?

Using your telephone keypad, simply dial 0800 328 9435 and select from the menu of options you will hear.

You will need to identify yourself by keying in your customer number (not your old delivery point code) and your secret pin. If you don't know these, please call 01273 421321 during working hours.

Using your phone keypad, simply key in the part numbers or answers to the prompts. You'll find the system easy to use, and extremely friendly. If you have any problems, our trained staff are on hand to help you during the working day.

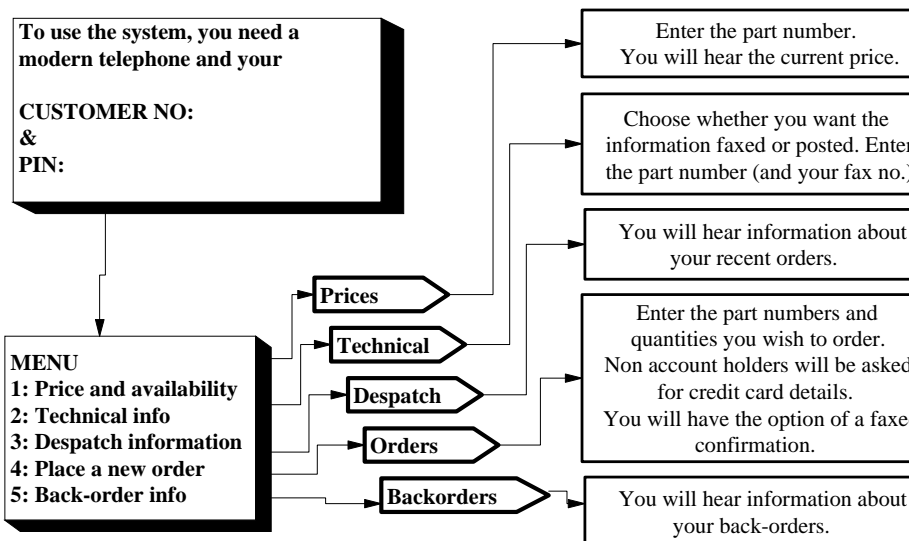

Tips:

Hash is the '#' key under the 9.

Be prepared. Write down all the information you will need before you call.

Use a tone telephone. If you hear tones when you dial (not clicks) then you have a tone phone. Many telephones have a small switch on the side to select DTMF tone dialling. A pulse telephone will not operate the system.

Write down the confirmation number. You will hear this when the order has been accepted.

*Call before 3pm on weekdays for same day despatch. **Free postage only applies to UK orders, and not to heavy or bulky items such as books, fluids, domes etc. or very low value orders. Cannot be used in addition to other special discounts.